

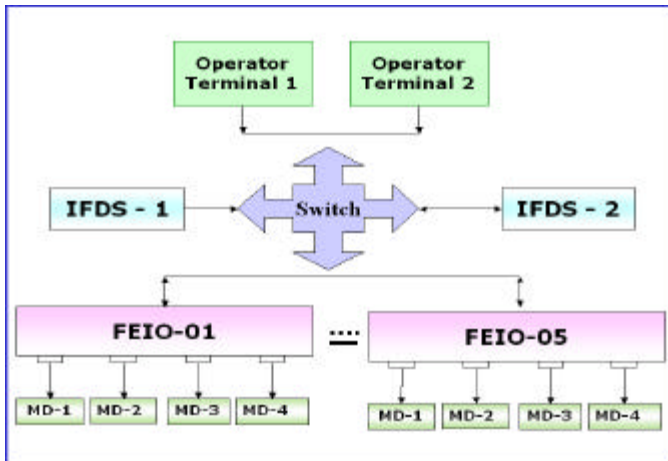

Internal Fraud Detection System

IFDS is a solution for any kind of basic Telecom Service provider that is facing revenue threats from the switch operating personnel/staff. In the process of day-to-day operation and maintenance activities, the switch-room operators use different MML commands on different Terminal Systems. Telecom switches maintain log of all those command transactions. This system collects that command transaction log and applies predefined algorithms to detect fraud / mistake occurred in the usage of the switch commands.

Architecture



SALIENT FEATURES

- ❖ Command-Log data collection from OMC port of the switch and transporting that Data to the central **IFDS Server**.
- ❖ Switch Access Modules for heterogeneous switches from ALCATEL's **E10B** & **OCB-283**, AT&T's **5ESS**, and Ericsson's **AXE-10**.
- ❖ Analysis of command-log and identifying the **frauds** and/or **mistakes** done by switch-room personnel in the usage of MML commands for day-to-day maintenance operations of the telecom switch.
- ❖ Subscriber Meter Reading Data Collection, providing Subscriber Call Usage Profile and providing MIS information of High Calling Group, Low Calling Group, etc. with Spurt & Dip analysis.
- ❖ Data Collection, Telecom Tariff information, Routing Information, Commands Usage information from the total Network and finding anomalies against standards set by the Telecom Service Provider.



- ❖ Informing the fraud / mistake occurred in the switch room within the next sixth (6th) minute after the occurrence of event.
- ❖ Designed and developed conforming to the guide lines mentioned partly in TEC GR for "**Fraud Management and Control Centre (FMCC)**", GR:G/FMC-01/01.JULY1999.

BENEFITS

- ❖ **Command Log Analysis**
 - Exchange-wise
 - OMC Port-wise
 - Command-wise
 - Unauthorized Access
 - Non-Password Access
- ❖ **Subscriber Feature Modifications**
 - Frequently Feature modified Numbers
 - Invalid Creation
- ❖ **Meter Reading based Subscriber Profiling**
 - Heavy Callers
 - Low Callers
 - Negative growth in Meter Reading
 - Spurt & Dip Analysis
- ❖ **Meter Reading of spare equipment**
 - Changes in **spare** equipment Readings
 - **Spare** Equipment Meter Reading **reset** for new Directory Number
- ❖ **Audit Charging**
 - Validation of **non-metered Levels**
 - Discrepancy in Charging bands
 - Invalid Charge Bands, Time Bands & Day-Types
 - Wrong Pulse Rates
 - Incorrect definition of Over-flow Trunk Groups
- ❖ **Monitoring Expensive Calls**
 - Expensive **Calls** by specific Directory Number / Equipment Number
 - User configurable **Thresholds** for Call Unit based Reports

HARDWARE ARCHITECTURE

UNIX based Dual-Processor, RAID-5 HDD based SERVER for **Server**, UNIX based Desktop systems for **MD** and **FEIO** and Windows based Desktop systems for Operator **Report Terminals**.